

DESCRIPTION

The Model WPM wideband power meter measures and displays voltage, current, power and energy parameters for single-phase or three-phase systems. Applications include measurement of PWM generated waveforms used in variable-frequency-drives (VFDs) and inverters. These units are also compliant with recent Department of Energy updates requiring 40th harmonic measurements (10 CFR Parts 429 and 431)

Local display is provided by three LED displays. Displayable parameters are grouped into four sets of three parameters each with the groups selectable by front panel push-button. Remote display modules may be added as required to provide dedicated display of up to eighteen different parameters.

Analog outputs may be provided by adding one or more D/A-4772 converters. Each of these converters provides up to eight output signals which may be assigned to any eight parameters.

Serial communications are provided through either an RS-232C, RS-422, RS-485 or USB interface, using a simple ASCII protocol. (USB is an external RS-232C-to-USB adapter.)



FEATURES

- High accuracy over a wide range of measurement.
- Suitable for applications with PWM-generated waveforms such as variable-frequency-drives (VFDs).
- Compliant with DoE requirements for 40th harmonic measurement (10 CFR Parts 429 and 431).
- Serial communication port options: RS-232C, RS-422, RS-485 or USB (using an external RS-232C-to-USB adapter)
- Simultaneous local display of three parameters on 5-digit, red, high-contrast LED displays.
- Measures true RMS voltage and current even with the presence of harmonics (distortion).
- Remote displays available.
- Analog output converters available.
- Current Transformers included.

MODEL SELECTION

WPM - [] - [] - [] - [] - [] - []

SYSTEM CONFIGURATION	VOLTAGE INPUT (Nominal)				CURRENT RANGE (A)	SERIAL COMM.	INSTRUMENT POWER	OPTIONS (leave blank for standard unit)						
	1Ø 2W	1Ø 3W	3Ø 3W	3Ø 4W										
1	1Ø 2W	1	120V _{L-N}	120V _{L-N} / 240V _{L-L}	120V _{L-L}	69V _{L-N} / 120V _{L-L}	1	0-100	1	RS-232C	1	115Vac	A	Without Local (front panel) Displays
2	1Ø 3W	2	240V _{L-N}	N/A	240V _{L-L}	120V _{L-N} / 208V _{L-L}	2	0-300	2	RS-422	2	230Vac	B	Streaming RS-485 for Remote Displays or D/A
3	3Ø 3W	3	480V _{L-N}	N/A	480V _{L-L}	277V _{L-N} / 480V _{L-L}	3	0-500	3	RS-485			**	Internal P.S. for up to 8 Remote Displays
4	3Ø 4W						4	0-800	4	External USB adapter				** More than 8 remote displays requires an external power supply.

ORDERING INFORMATION

Example: System = 3Ø 3W, Voltage = 0-240V_{L-L}, Current = 0-100A, Serial Communications = USB, Instrument Power = 115Vac, with local displays (no options)

WPM-3-2-1-4-1

Measured parameters, local display arrangement, communication data strings, etc. may be customized by completing a Configuration Worksheet (pg 4) at time of ordering

SPECIFICATIONS**INPUT**

Voltage
 Nominal See table
 Range 0-125% of Nominal
 Over-range (w/o damage)..... 150% of Nominal
 Burden (at max. input)..... 0.5mA per phase

Current
 Range see table
 Over-range (with linearity) 115% of range
 (w/o damage)..... 150% of range

Frequency
 Range (fundamental) 10-130Hz
 Note: Accuracy statement includes up to 10% content of
 40th harmonic at 60Hz (2400Hz) to comply with updated
 DoE requirements.

Power Factor Any

INSTRUMENT POWER

"-1" 115Vac ±15%, 50/60Hz, 10VA
 "-2" 230Vac ±15%, 50/60Hz, 10VA

SERIAL COMMUNICATIONS

"-1" (9 pin D-sub) RS-232C
 "-2" (9 pin D-sub) RS-422
 "-3" (9 pin D-sub) RS-485
 "-4" (USB spec. 1.1 or later) USB
 (external RS-232C-to-USB adapter)
 ASCII communication protocol for all formats is described
 later in this document.

ACCURACY (setpoint, linearity and repeatability)

Voltage, Current, Power (VA, VARs, Watts), Energy
 10% - 100% of range ±0.25% F.S.
 Power Factor ±0.02PF
 Frequency ±0.1% Rdg., ±0.1% F.S.

DIELECTRIC TEST

Input/Output/Instrument Power 1800Vac

TEMPERATURE

Operating Range 0°C to 50°C
 Effect ±0.005%/°C, ±0.05% F.S.

PHYSICAL

Operating Humidity 0-95% non-condensing
 Weight 2.75lb.

ENCLOSURE Noryl SE 1, UL94V-1, IP 40, Black

OPTIONAL ACCESSORIES (consult factory)

1. Remote display (P/N 21967): 5 digit, LED, up to 18 per unit.
2. Analog output converter (P/N D/A-4772): 8 channels each.

CONFIGURATION

Refer to the Configuration sheet supplied with each unit for specific information regarding the choice of measured parameters, local display arrangement, etc. (sheet is identified by serial number of unit). When ordering, complete Configuration Worksheet (pg 4) to specify display

OPERATION

Locally displayed parameters are arranged in four groups of three and are identified by the matrix to the right of the displays. Parameter combinations are labeled in the columns above each of the four indicator LEDs. The column being displayed is indicated by a lit LED.

Up/Down arrow buttons select columns to display: Up selects next column to the right, Down selects next one to the left.

Press and hold the front panel SELECT button for approximately two seconds to reset the Wh display to zero.

When configured as a 'Freeze/Unfreeze' control (see communication CF command) the Menu button will 'Freeze' all data values. The Up and Down arrow buttons may be used to display 'Frozen' values. Pressing the Menu button again will 'Unfreeze' data and allow normal updating.

When configured as a Standard/Extended averaging control (this is the default, see also communication command CA) the Menu button will toggle the data update rate between Standard (approximately 2.5 times per second) and Extended (approximately once every 3 seconds). Extended averaging is active when the Menu button LED is lit.

DEFAULT CONFIGURATIONS FOR LOCAL DISPLAYS ARE AS FOLLOWS:

1Ø 2W Units ("-1")

	<u>First LED is lit (pos.)</u>	<u>Second LED is lit (pos.)</u>	<u>Third LED is lit (pos.)</u>	<u>Fourth LED is lit (pos.)</u>
Top Display	= Volts 1	= Watt-Hours 4	-	-
Middle Display	= Amps 2	= Power Factor 5	-	-
Bottom Display	= Watts 3	= Frequency 6	-	-

1Ø 3W Units ("-2")

	<u>First LED is lit (pos.)</u>	<u>Second LED is lit (pos.)</u>	<u>Third LED is lit (pos.)</u>	<u>Fourth LED is lit (pos.)</u>
Top Display	= Volts Avg L-N 1	= Watt-Hours 4	= Volts L1-N 7	= Amps L1 10
Middle Display	= Amps Avg 2	= Power Factor 5	= Volts L2-N 8	= Amps L2 11
Bottom Display	= Watts Sys 3	= Frequency 6	= Volts L1-L2 9	= - 12

3Ø 3W Units ("-3")

	<u>First LED is lit (pos.)</u>	<u>Second LED is lit (pos.)</u>	<u>Third LED is lit (pos.)</u>	<u>Fourth LED is lit (pos.)</u>
Top Display	= Volt Avg L-L 1	= Watt-Hours 4	= Volts L1-L2 7	= Amps L1 10
Middle Display	= Amps Avg 2	= Power Factor 5	= Volts L2-L3 8	= Amps L2 11
Bottom Display	= Watts Sys 3	= Frequency 6	= Volts L3-L1 9	= Amps L3 12

3Ø 4W Units ("-4")

	<u>First LED is lit (pos.)</u>	<u>Second LED is lit (pos.)</u>	<u>Third LED is lit (pos.)</u>	<u>Fourth LED is lit (pos.)</u>
Top Display	= Volt Avg L-N 1	= Watt-Hours 4	= Volts L1-N 7	= Amps L1 10
Middle Display	= Amps Avg 2	= Power Factor 5	= Volts L2-N 8	= Amps L2 11
Bottom Display	= Watts Sys 3	= Frequency 6	= Volts L3-N 9	= Amps L3 12

Each WPM unit may be configured to measure any 18 parameters from the following list. Any 12 of those 18 parameters may be selected for local display. Display position is selectable. Any or all of the parameters may also be accessed through the communication port, be remotely displayed (1 parameter per display) or sent to a D/A converter to provide analog output signals (8 channels per converter).

Check the boxes below to indicate the desired configuration for WPM - _____

PARAMETERS	MEASURED	DISPLAYED	POSITION #		MEASURED	DISPLAYED	POSITION #		MEASURED	DISPLAYED	POSITION #
<u>VOLTS (L-N)</u>				<u>VOLTS (L-L)</u>				<u>AMPS</u>			
L1-N..... <input type="checkbox"/> <input type="checkbox"/> _____				L1-L2..... <input type="checkbox"/> <input type="checkbox"/> _____				L1..... <input type="checkbox"/> <input type="checkbox"/> _____			
L2-N..... <input type="checkbox"/> <input type="checkbox"/> _____				L2-L3..... <input type="checkbox"/> <input type="checkbox"/> _____				L2..... <input type="checkbox"/> <input type="checkbox"/> _____			
L3-N..... <input type="checkbox"/> <input type="checkbox"/> _____				L3-L1..... <input type="checkbox"/> <input type="checkbox"/> _____				L3..... <input type="checkbox"/> <input type="checkbox"/> _____			
Average L-N .. <input type="checkbox"/> <input type="checkbox"/> _____				Average L-L..... <input type="checkbox"/> <input type="checkbox"/> _____				Average..... <input type="checkbox"/> <input type="checkbox"/> _____			
<u>WATTS</u>				<u>VOLT-AMPS</u>				<u>VARs</u>			
L1-N..... <input type="checkbox"/> <input type="checkbox"/> _____				L1-N..... <input type="checkbox"/> <input type="checkbox"/> _____				L1-N..... <input type="checkbox"/> <input type="checkbox"/> _____			
L2-N..... <input type="checkbox"/> <input type="checkbox"/> _____				L2-N..... <input type="checkbox"/> <input type="checkbox"/> _____				L2-N..... <input type="checkbox"/> <input type="checkbox"/> _____			
L3-N..... <input type="checkbox"/> <input type="checkbox"/> _____				L3-N..... <input type="checkbox"/> <input type="checkbox"/> _____				L3-N..... <input type="checkbox"/> <input type="checkbox"/> _____			
System..... <input type="checkbox"/> <input type="checkbox"/> _____				System..... <input type="checkbox"/> <input type="checkbox"/> _____				System..... <input type="checkbox"/> <input type="checkbox"/> _____			
<u>ENERGY (Wh)</u>				<u>FREQUENCY</u>				<u>POWER FACTOR</u>			
System..... <input type="checkbox"/> <input type="checkbox"/> _____				System..... <input type="checkbox"/> <input type="checkbox"/> _____				System..... <input type="checkbox"/> <input type="checkbox"/> _____			

SCALING

VOLTAGE..... Direct Input Only
 Scaled For Use With PTs. Ratio _____ : _____
 Cal. with _____ PTs. (OSI P/N or "customer-supplied")

D/A-4772x ... Calibrate with D/A-4772x S/N: _____

RESOLUTION

Units of measurement and resolution are factory-selected to provide the best reasonable resolution (i.e. W/KW/MW, 00000/0000.0/0.0000, etc).

Example: Full Scale Watts = Volts(L-N) * Current * 3
 346VL-N * 500A * 3 = 519KW = F.S. (the factory default resolution would be 519.0KW)

BIDIRECTIONAL OPERATION

WATTS

Note: Reverse power will be indicated with a "-" sign. Resolution must be adjusted to use 4 digits of display only. Otherwise the "-" sign will overwrite the most significant digit. (Watthour operation is unidirectional (forward energy) even if bidirectional Watt operation is selected.)

COMMENTS: _____

OSI Approval _____ Date _____ Customer Approval _____ Date _____ S.O.# _____
 (Initials) (Initials)

GENERAL

- “-1”
- Format: RS-232C, 3-wire interface (without handshaking)
 Parameters: 9600 baud, no parity, 8 data bits, 1 stop bit (N, 8, 1)
 Connector: 9 pin, male (DB-9P), Pin 2 = RX, Pin 3 = TX, Pin 5 = Com
 Configuration: This is a DTE device. To communicate with another DTE device, such as a PC, a null modem (cross-over) cable must be used. Communication with DCE devices (generally anything other than a PC) requires a straight-through RS-232C cable.
- “-2”
- Format: RS-422
 Parameters: 9600 baud, no parity, 1 stop bit (N, 8, 1)
 Connector: 9 pin, male (DB-9P), Pin 4 = TX+, Pin 5 = TX-, Pin 8 = RX+, Pin 9 = RX-.
- “-3”
- Format: RS-485
 Parameters: 9600 baud, no parity, 1 stop bit, (N, 8, 1)
 Connector: 9 pin, male (DB-9P), Pins 4 and 8 = TX/RX+, Pin 5 and 9 = TX/RX-
- “-4”
- Format: External RS-232C-to-USB adaptor. Compliant with USB specification 1.1 or later.

MESSAGE FORMAT

All commands and responses have the same general format: STX ADDR CMD DATA ETX

STX	ASCII start of text character, control B (^B).
ADDR	Unique 4 character address for each meter. Hex characters 0-F are allowed. (Default = 0001)
CMD	A two-character command for which there is a defined response.
DATA	Information associated with the command where required.
ETX	ASCII end of text character, control C (^C).

COMMAND DESCRIPTION

Configuration of communication strings (RD and RR) will vary from unit to unit based on customer requirements. The following examples are based on factory default settings. Refer to the configuration sheet supplied with each unit for specific information (sheet is identified by serial number of unit).

RD	Read Data	Meter responds with 9 data values (6 digits ea w/decimal point) as a comma-delineated string: WSYSTEM, PFSYSTEM, Hz, VL1-N, VL2-N, VL3-N, IL1, IL2, IL3
RR	Read Register	Meter responds with 9 data values (6 digits ea w/decimal point) as a comma-delineated string: VL1-L2, VL2-L3, VL3-L1, WL1-N, WL2-N, WL3-N, VASYSTEM, VARSYSTEM, WHSYSTEM
FD	Freeze Data	All data values are 'Frozen' simultaneously. 'Frozen' values may still be read using the RD and RR commands. 'Frozen' values may still be displayed using the front panel push-buttons. The CF command may be used to configure the unit so that pressing the front panel Menu button will 'Freeze' data.
UD	Unfreeze Data	All data values are 'Unfrozen' and return to normal updating. The CF command may be used to configure the unit so that pressing the front panel Menu button while frozen data is displayed will 'Unfreeze' data.
CE	Clear	Clears accumulated Watthour values. This command has the same effect as pressing the front panel Select button.
CF	Configure	Configure the front panel Menu button to act as a Freeze/Unfreeze control.
CA	Configure	Configure the front panel Menu button to act as a Standard/Extended Averaging control for data updates.
WU	Write Unit	Used to set unit address.
V1	Verify	Meter responds with unit address and firmware version.

NOTE: The rear panel Program Enable jumper must be installed to allow the WU, CA and CF commands to store settings in non-volatile memory. Configuration will revert to the previous setting(s) at the next instrument power ON/OFF cycle if the jumper is not installed.

COMMAND and RESPONSE EXAMPLES

Configuration of communication strings (RD and RR) will vary from unit to unit based on customer requirements. The following examples are for illustration only and assume a unit address of 0001. Refer to the configuration sheet supplied with each unit for specific information (sheet is identified by serial number of unit).

Command:	RD	STX ADDR RD ETX ^B0001RD^C	(Read data string 1)
Response:		STX ADDR,WsYS,PFsYS,HZ,V _{L1-N} ,V _{L2-N} ,V _{L3-N} ,I _{L1} ,I _{L2} ,I _{L3} ,ETX ^B0001,05190.0,0001.00,0060.00,00346.0,00346.0,00346.0,005.000,005.000,005.000,^C	
Command:	RR	STX ADDR RR ETX ^B0001RR^C	(Read data string 2)
Response:		STX ADDR,V _{L1-L2} ,V _{L2-L3} ,V _{L3-L1} ,W _{L1-N} ,W _{L2-N} ,W _{L3-N} ,VAsYS,VARsYS,WHsYS,ETX ^B0001,00600.0,00600.0,00600.0,01730.0,01730.0,01730.0,05190.0,05190.0,^C	
Command:	FD	STX ADDR FD ETX ^B0001FD^C	(Freeze data)
Response:		STX ADDR FD ETX ^BFD^C	(Command echo)
Command:	UD	STX ADDR UD ETX ^B0001UD^C	(Unfreeze data - resume normal updating)
Response:		STX ADDR UD ETX ^BUD^C	(Command echo)
Command:	CE	STX ADDR CE ETX ^B0001CE^C	(Reset accumulated Watt-Hour data)
Response:		STX CMD ETX ^BCE^C	(Command echo)
Command	CF	STX ADDR CF ETX ^B0001CF^C	(Configure Menu button for Freeze/Unfreeze control)
Response		STX CF ETX ^BCF^C	(Command echo)
Command	CA	STX ADDR CA ETX ^B0001CA^C	(Configure Menu button for Standard/Extended averaging control)
Response		STX CA ETX ^BCA^C	(Command echo)
Command:	WU	STX ADDR CMD DATA ETX ^B0001WU0009^C	(Change address from 0001 to 0009)
Response:		STX CMD ETX ^BWU^C	(Command echo)
Command:	V1	STX ADDR CMD ETX ^B0000V1^C	(Verify address and firmware version)
Response:		STX ADDR Version ETX ^B00090301^C	(Address is 0009, firmware version is 0301)

NOTES

1. Universal address is 0000 and may be used to verify or write a new address.
2. Never use the universal address with multiple units connected to the same communication line.
3. When the universal address is used there is no command echo.
4. Read commands do not respond to the universal address.
5. Commands may be either upper or lower case.
6. **DO NOT send more than one command per second (such as via LabView software).**

PANEL MOUNT ENCLOSURE

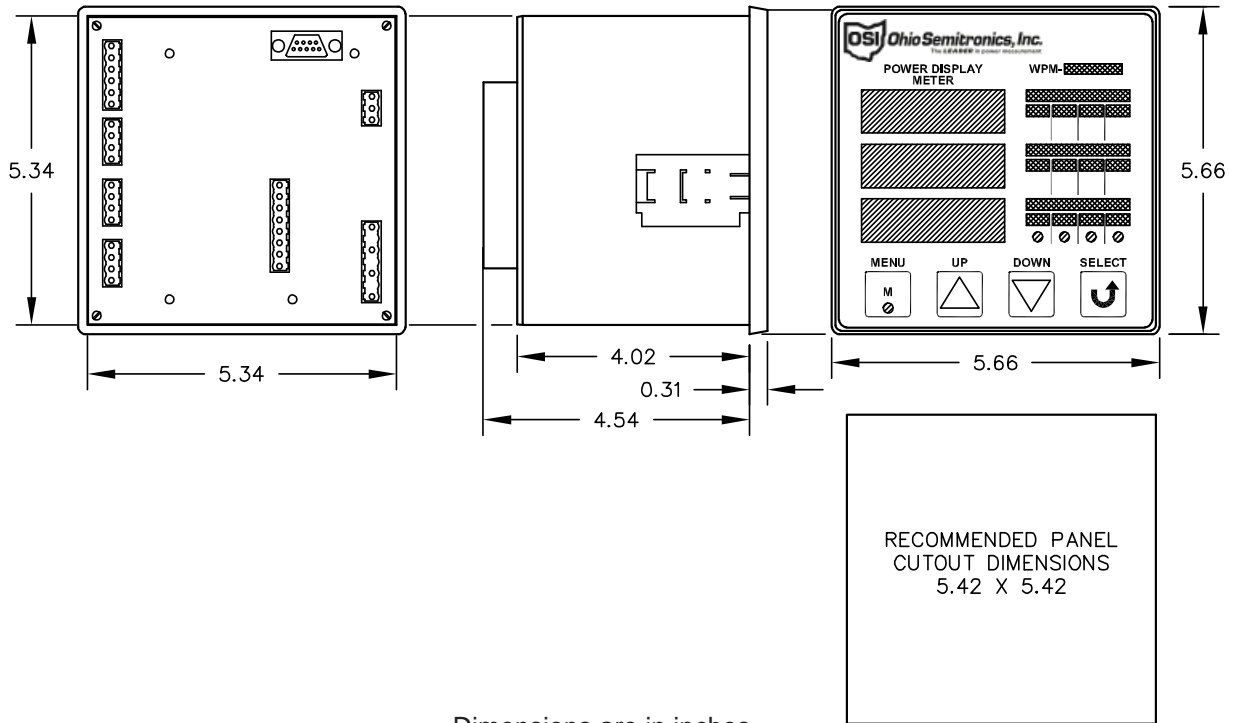

Dimensions are in inches

Dwg# 0902-01033-B Rev -A

CURRENT TRANSFORMERS

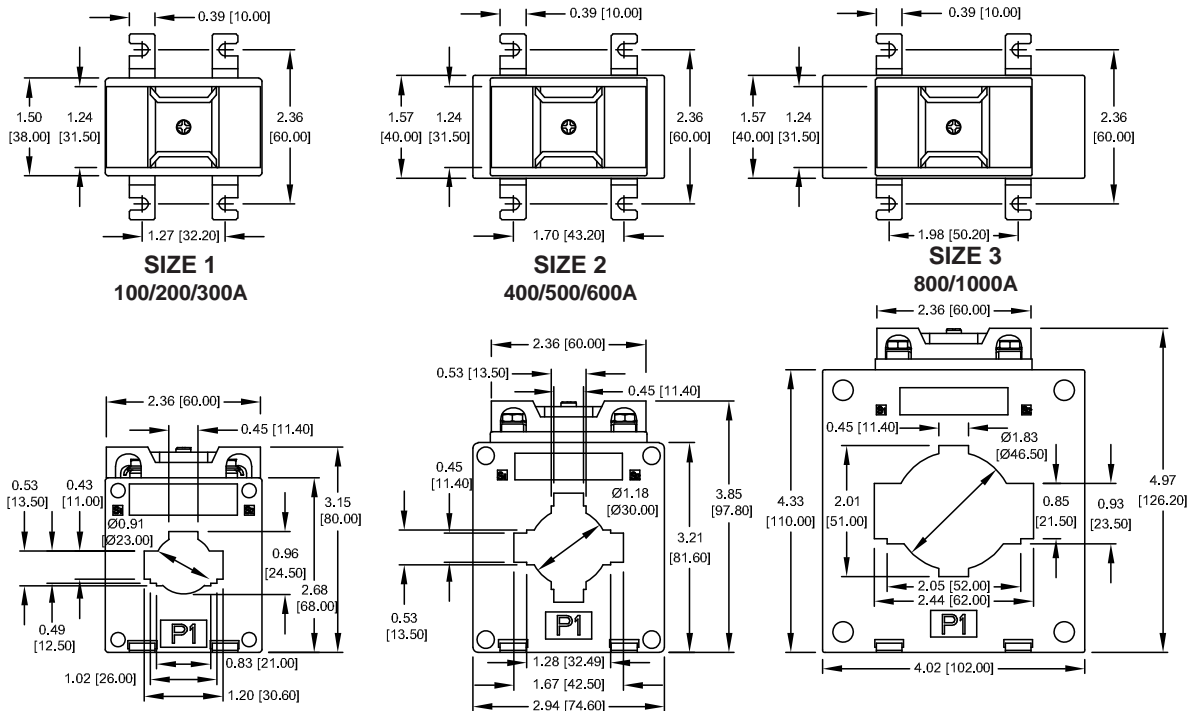

All dimensions in inches [millimeters]

Dwg# 0902-01025-B Rev-A

SINGLE-PHASE, 2-WIRE

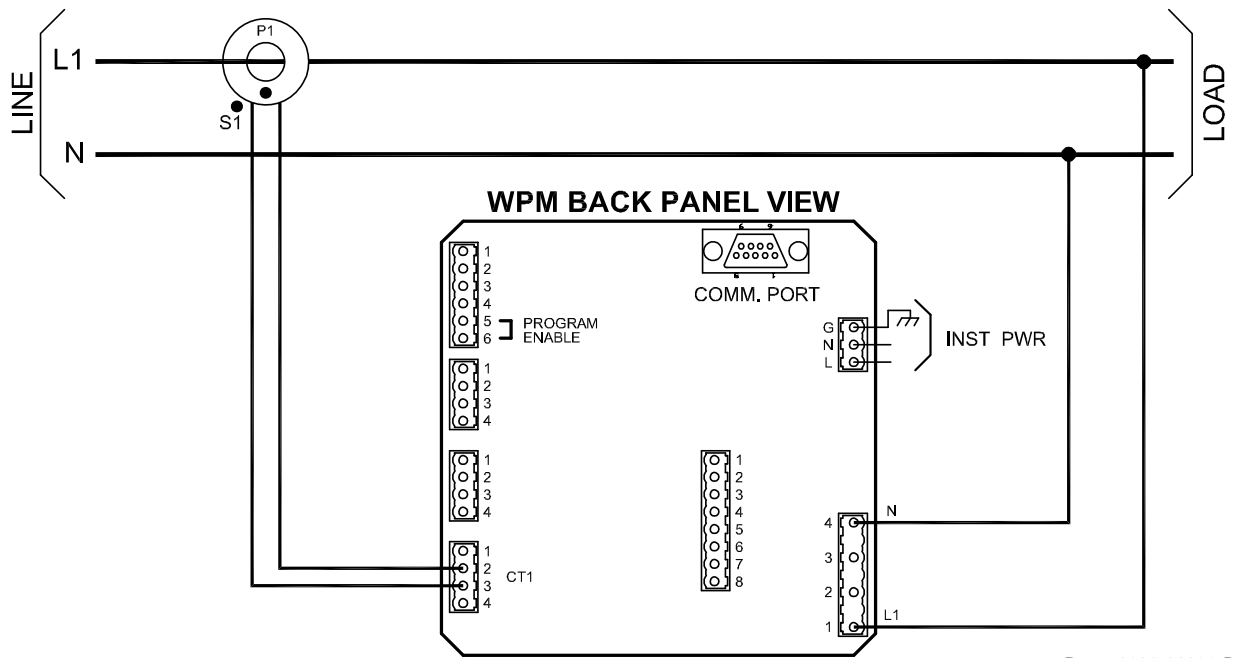

Dwg# 0902-01033-B Rev-A

SINGLE-PHASE, 3-WIRE

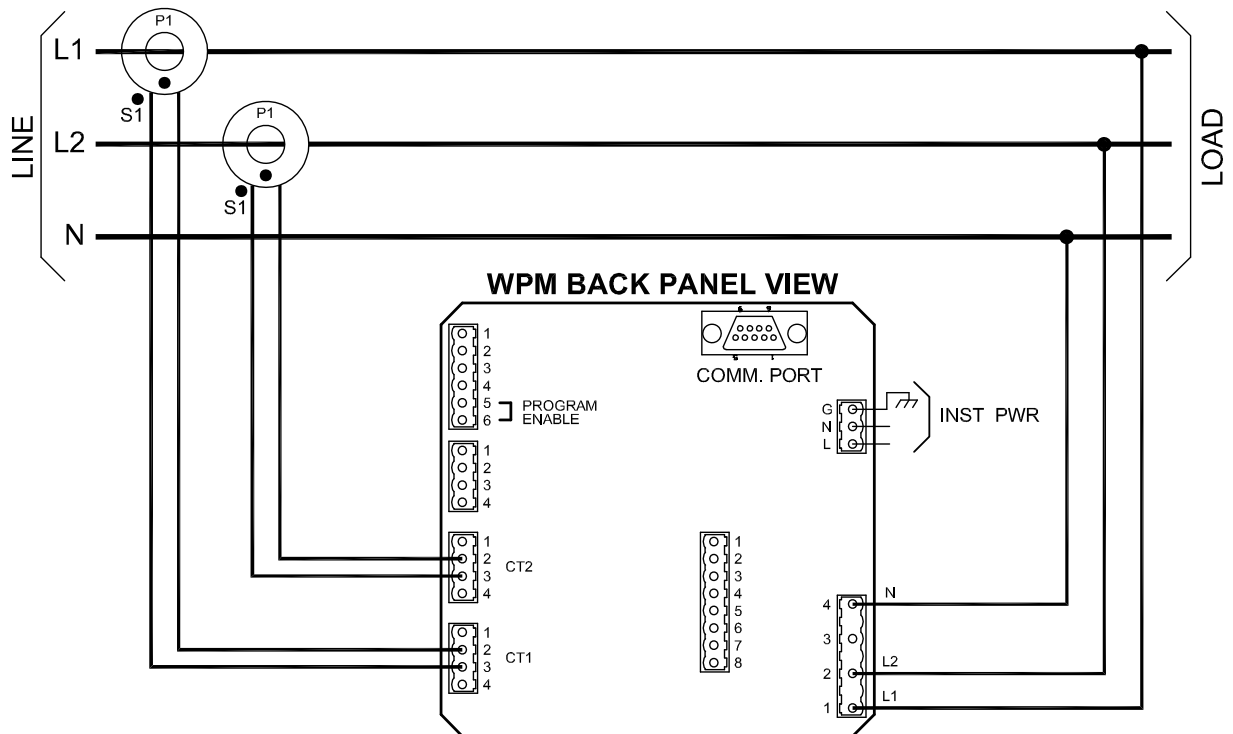

Dwg# 0902-01033-B Rev-A

THREE-PHASE, 3-WIRE

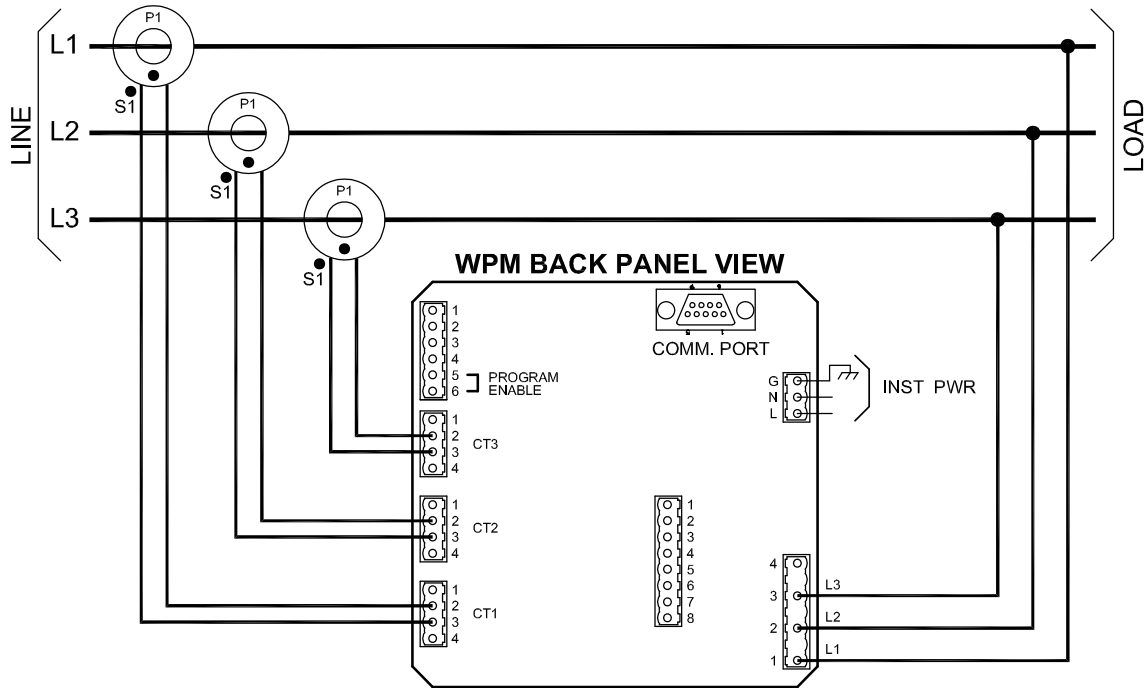

Dwg# 0902-01033-B Rev-A

3-PHASE, 4-WIRE

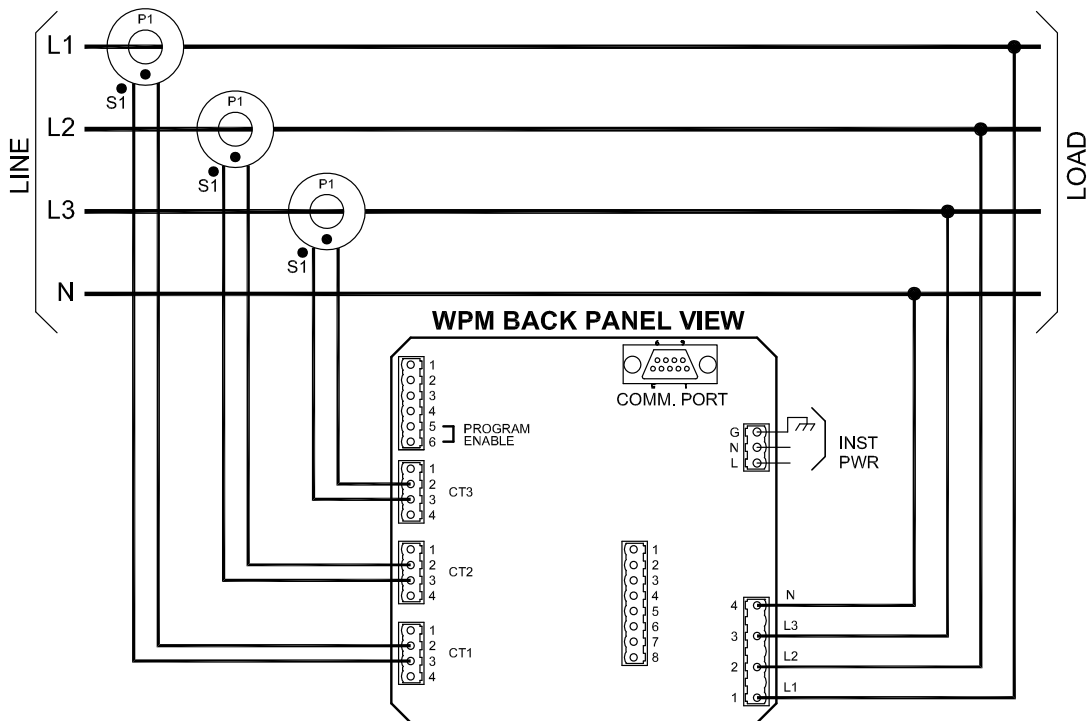

Dwg# 0902-01033-B Rev-A

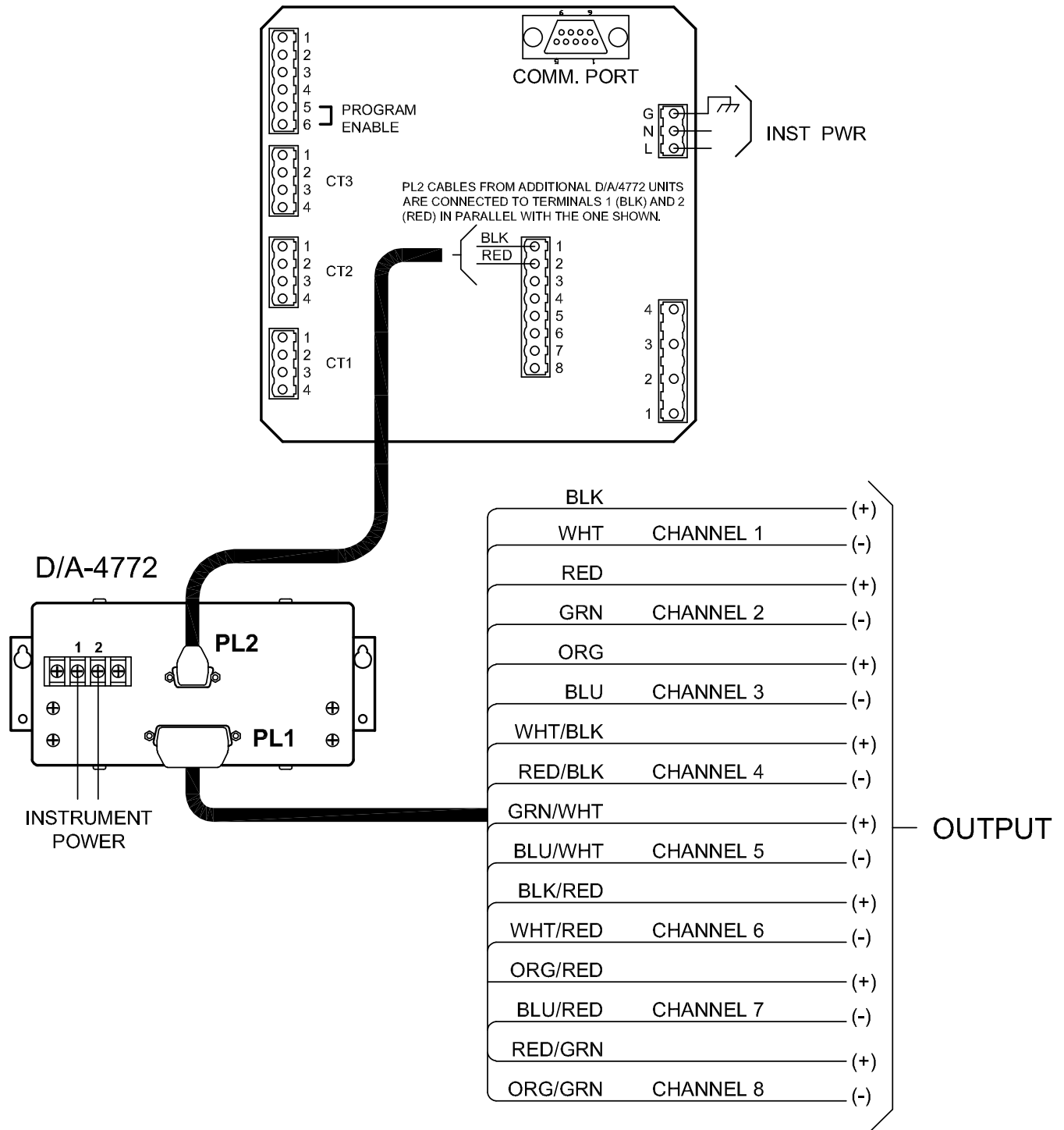

Dwg# 0902-01033-B Rev-A