

DESCRIPTION

The Model CMS-400C monitors load currents of devices such as fans, pumps and other critical items in HVAC systems. The solid-state relay output provides a run-status indication for these devices to compatible DDC/PLC control systems. The relay output of this model is completely isolated from the input current.

Units with the VF option are suitable for use in Variable Frequency Drive (VFD) systems with a frequency range of 12 to 60Hz. (order Model CMS-400C-VF)

NOTE: CMS-400C was previously CMS-400C-N.O.



SPECIFICATIONS

INPUT

Current Range..... 5-140A
 Frequency
 Standard 60Hz
 With VF option 12-60Hz

OUTPUT

Solid State Relay..... Form A, Normally Open, 120V, 2A, dc or ac noninductive
 Response Time ...Nominal25ms
 With VF option2s
 Threshold Setting Adjustable from 5-140A
 Relay Action Load current *under* threshold = Open
 Load current *over* threshold = Closed

INSTRUMENT POWER

All models..... Self Powered

TEMPERATURE

Operating Range..... 10°-135°F

PHYSICAL

Enclosure ABS, Cyclac® , UL94V-0, Black
 Net Weight..... 0.25lb

CONNECTIONS

Input Current-carrying cable is inserted through circular window opening. Maximum cable size #3/0 (dia. <0.62")
 Output Wire-retaining screw terminals No. 6/32 Maximum wire size #14 AWG

DIMENSIONS

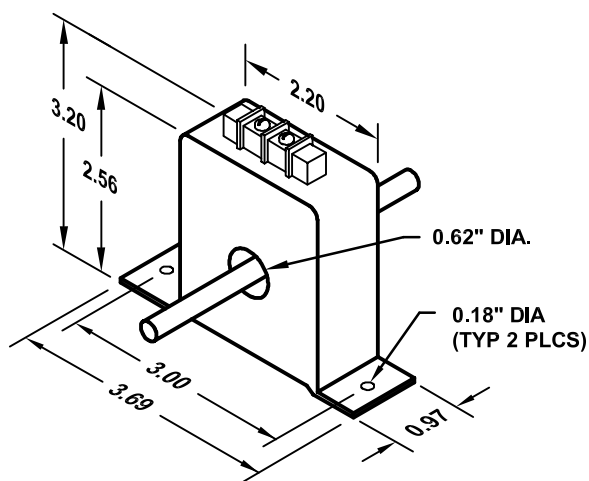

CONNECTION DIAGRAM

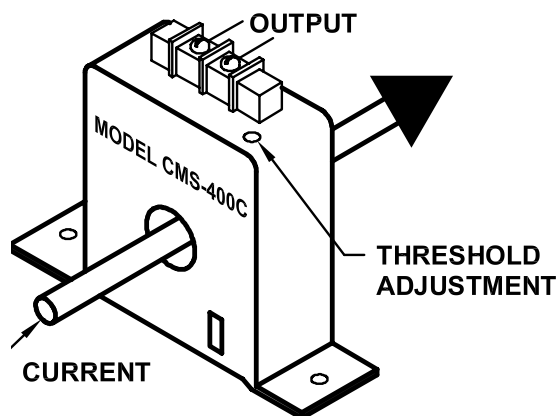

INSTALLATION

1. The CMS-400C may be mounted in any type of protected enclosure, motor starter, motor control center, control system field panel, or disconnect switch.
2. The current-carrying cable must pass through the circular window opening. Permanently affix the CMS-400C to the cable with a conventional cable tie or similar non-conductive material. The unit may be oriented in any position.
3. Alternatively the CMS-400C may be mounted to any flat surface, such as the back panel of the enclosure - see Case Dimensions for mounting dimensions.
4. Should mounting space be limited, the mounting feet of the CMS-400C may be snapped off.

SET-UP

1. After the CMS-400C has been installed, energize the load and observe the solid state relay output status.
2. If the relay is not open then turn the threshold adjustment counter-clockwise until the relay is open.
3. Next turn the adjustment clockwise until the relay closes.
4. Setup is now complete. Cycle the load and observe operation.
5. When load current is under threshold setting the relay will be open.
6. When load current is over the threshold setting the relay will be closed.

Note 1: For load amperages greater than 140Aac use an external current transformer (C.T.) of an appropriate ratio such as 500:5. Feed the C.T. secondary through the CMS-400C window with one pass. Adjust the threshold setting as described above.

Note 2: The CMS-400C current switch uses a solid-state relay output. Contact closure can be verified by a continuity meter.

Note 3: The CMS-400C solid-state relay output may be used to switch either dc or ac noninductive loads of up to 120V and 2A.

Note 4: The CMS-400C must have at least 5A through the window opening. For loads less than 5A, place enough additional turns of the main current-carrying cable through the window to provide at least 5 Ampere-turns.

Example: 1 Amp load - use 5 turns for 5 Ampere-turns
2 Amp load - use 3 turns for 6 Ampere-turns
3 Amp load - use 2 turns for 6 Ampere-turns
4 Amp load - use 2 turns for 8 Ampere-turns