



OPERATION, INSTALLATION & CALIBRATION MANUAL

CT5, ACT5, ACT, 3CT5, 3ACT, UC, AND MCT5 CURRENT TRANSDUCERS

By David W. MILLER

Edited and revised by William D. Walden January 1999

OHIO SEMITRONICS, INCORPORATED

© Copyright by Ohio Semitronics, Inc. January 1999



CT5, MCT5, & 3CT5 SHOWN ABOVE

OHIO SEMITRONICS, INC.

4242 Reynolds Drive

Hilliard, Ohio 43026

Phone: 614-777-1005

Fax: 614-777-4511

E-mail: sales@ohiosemitronics.com

<http://www.ohiosemitronics.com>

CT5 FAMILY MANUAL Price \$15.00
Drawing Number 7004-27 January 26, 1999
Rev. 1/26/99
W. D. Walden

PREFACE TO THE CT5 FAMILY MANUAL

By William D. Walden

The CT5 Family includes the following model series:

- CT5
- 3CT5
- ACT5 (UL Listed version to be discontinued March 1999 and replaced by the ACT.)
- ACT (UL and CUL Listed, CE)
- 3ACT (UL and CUL Listed, CE)
- MCT (DIN Rail Mount Version of the CT5)
- UC (Utility grade version of the CT5)

Not covered in this manual are:

- CTD (Current transformer and electronics in the same case.)
- SCT (Split core current transformer and electronics in the same case.)

All of the above current transducers are absolute average measuring, rms calibrated (or mean value measuring, rms calibrated).

These inexpensive transducers simply convert the AC input to DC and have the output calibrated to represent the root mean square (RMS) value for sine wave input. This type is very adequate for situations in which the current wave shape is not distorted. Any odd harmonic or discontinuity will introduce large error. Use the true RMS measuring type when distortion of a sine wave is present.

When calibrating these transducers you must use a current source that provides a pure sine wave source.

The UC versions must be linear and within their rated accuracy to 10 amperes. The nominal rating for the UC series current transducers is 5 amperes.

David W. Miller and Jack Warnock designed the transducers in the above series.

David W. Miller is Vice President of Ohio Semitronics, Inc. He has been with the company since its founding in 1964. Mr. Miller personally designed most of the transducers that Ohio Semitronics, Inc. is presently manufacturing.

Jack Warnock is a design engineer at Ohio Semitronics, Inc. Jack has been with Ohio Semitronics, Inc. since December 1994 and has designed a number of new transducers for us.

Lewis Miller worked to obtain the UL and CUL Listings and the CE rating for the ACT series. Lewis Miller has been with OSI since 1976. He has designed many of the instruments manufactured by Ohio Semitronics, Inc.



CALIBRATION MANUAL FOR CT5, ACT5, ACT, 3CT5, 3ACT, UC, AND MCT5 CURRENT TRANSDUCERS

SUBJECT

Calibration of the following models:

- **CT5-001 through CT5-1500** with options A, E, or E2.
- **ACT5-001A** (Discontinued after March 1999 use the ACT-005A if your are replacing.)
- **ACT-001 through ACT-1500** with options A, C, CX5, E, or E2. (All are UL and CUL Listed, and CE rated.)
- **3CT5-001 through 3CT5-1500** with options A, E, or E2.
- **3ACT-001 through 3ACT-1500** with options A, C, CX5, E, or E2. (All are UL and CUL Listed, and CE rated.)
- **UC0006001** (Single) or **UC0006401** (Triple)
- **MCT5-001 or MCT5-005** with options A , E, or E2

DESCRIPTION

All of the above current transducers are absolute average measuring, rms calibrated (or mean value measuring, rms calibrated).

These inexpensive transducers simply convert the AC input to DC and have the output calibrated to represent the root mean square (RMS) value for sine wave input. This type is very adequate for situations in which the current wave shape is not distorted. Any odd harmonic

or discontinuity will introduce large error. Use the true RMS measuring type when distortion of a sine wave is present.

The suffix letter indicates the type analog output that these transducers have. The letter designations are:

Option	Output	Instrument power
A	0 to 1 mADC	none required
C	0 to 10 volts DC	none required
CX5	0 to 5 volts DC	none required
E	4 to 20 mADC	120 VAC
E2	4 to 20 mADC	15 to 35 volts DC in External loop.

Please note that not all models are available with all the output options.

Models that have the prefix 2 or 3 are double or triple models (2 or 3 elements in the same can). Each element requires the same calibration as individual transducers.

All of these models have essentially the same circuit.

Ohio Semitronics, Inc. recommends checking calibration for critical applications annually.

TEST EQUIPMENT REQUIRED

- 1) AC sine wave current source capable of supplying 60 hertz (or desired frequency 50 to 400 hertz) at the full scale specified current. **Note: Current source must produce sine wave current.**
- 2) Ammeter to measure the input current with an accuracy of 0.05% or better.
- 3) DC milliamperemeter or voltmeter to measure the output with an accuracy of 0.05% or better. A precision resistor may be substituted to measure transducers with a milliamperemeter output. Recommended values are:

For 0 to 1mADC use a 1000 ohm resistor.

For 4 to 20 mADC use a 250 ohm resistor.

Tolerances must be 0.05% or better.

If a high current source is not available, multiple turns through the current transformer window may be used. For example if you are calibrating a CT5-100A and have a 10 ampere source, you may use ten turns through the transformer window.

Please note that all CT5 and ACT with current ratings greater than 20 amperes are supplied with current transformers and were factory calibrated with the transformer supplied. To maintain the factory accuracy rating, these models must be calibrated with the current transformer supplied.

Calibrate at the frequency at which the transducer will be used.

CONNECTIONS AND ADJUSTMENTS

Make the connections as shown on page 5 & 6 for your model. All adjustments are made

through the lid. Remove the plastic caps and use a 1/8 inch wide screwdriver to make the adjustments to the trimpots.

Zero Adjust

No zero adjustment is required for models except the 4 to 20 mADC output option E or E2.

Option E or E2

Apply instrument power and allow the transducer to “warm up” for 15 minutes. With no current applied to the input terminals, adjust the zero trimpot for 4.000 mADC. (If you are using a 250 ohm load resistor, set the trimpot for 1.000 volt DC.)

Calibration Adjust

The “Cal” adjustment sets the output for the full-scale input current.

Option A:

- 1) Adjust the input current for the full scale rating of the transducer being calibrated.
- 2) If you are using a milliamperemeter adjust the “Cal” trimpot for an output of 1.000 mADC.
- 3) If you are using a voltmeter and 1000 ohm resistor to load the output, adjust the “Cal” trimpot for 1 .000 volt.

Option C:

- 1) Adjust the input current for the full scale rating of the transducer being calibrated.
- 2) Adjust the “Cal” trimpot for an output of 10 volts.

Option CX5:

- 1) Adjust the input current for the full scale rating of the transducer being calibrated.

- 2) Adjust the “Cal” trimpot for an output of 5 volts.

Option E:

- 1) Perform the zero adjust first.
- 2) Adjust the “Cal” trimpot for an output of 20 mADC
- 3) If you are using a 250 ohm load resistor and a voltmeter, adjust the “Cal” trimpot for an output of 5 volts.

Option E2:

This is the same, as E above except you must have a 24-volt DC supply in the output circuit as shown on page 7.

If this is a 2 or 3 element model, repeat the above for each element.

UC Models

UC models must be checked from 0 to 10 amperes for linearity. UC0006001 and UC0006401 have a full scale rating of 5 amperes. They must be linear to 10 amperes.

- 1) Adjust the input current for the full scale rating of 5 amperes at 60 hertz.
- 2) If you are using a milliampere meter adjust the “Cal” trimpot for an output of 1.000 mADC.
- 3) If you are using a voltmeter and 1000 ohm resistor to load the output, adjust the “Cal” trimpot for 1.000 volts.
- 4) Adjust the input current for 10 amperes.
- 5) If you are using a milliampere meter check to ensure that the output is 2.000 ± 0.0025 mADC.
- 6) If you are using a voltmeter and 1000 ohm load resistor, check to ensure that the output is 2.000 ± 0.0025 volts DC.
- 7) If you are calibrating a model UC0006401, repeat above for each element.

LINEARITY CHECK

Starting at 100% of the full-scale current and measuring the analog output of the transducer one may check linearity of the current transducers.

Reduce the current in steps of 20% from full scale to 0 measuring the analog output at each step. Please refer to Table 1 on the next page.

UC models must be checked at 200% of full scale.

Should a transducer fail to meet the linearity check, try adjusting the full scale output slightly up or down to bring the entire output range into the specified accuracy for the transducer. If this does not bring the linearity into specification, consider returning the transducer to Ohio Semitronics, Inc. for linearization.

Calibration Equipment

Ohio Semitronics, Inc. recommends calibration equipment that sources the current. We suggest the following:

Rotek Model 8000 or 800
Rotek Instrument Corp.
390 Main Street
PO Box 504
Waltham, MA 02254-0504
617-899-4611
sales@rotek.com

Arbiter Model 931A Power Analyzer for a standard meter.
Arbiter Model 1040C Meter Calibrator.
Both Arbiter units are available for purchase from Ohio Semitronics, Inc.
Sales@ohiosemi.com

	OUTPUT FROM TRANSDUCER.					
Rated Full Scale	1 mADC	1 volt DC	5 volt DC	10 volt DC	4 to 20 mADC	1 to 5 volt DC
Per Cent of Full Scale						
200% UC models only	2.0 mADC	2.0 volts DC				
120% (Optional check)	1.2 mADC	1.2 volts DC	6.0 volts DC	12.0 volts DC	23.2 mA	5.8 volts
100%	1.0 mADC	1.0 volts DC	5.0 volts DC	10.0 volts DC	20.0 mA	5.0 volts
80%	0.8 mADC	0.8 volts DC	4.0 volts DC	8.0 volts DC	16.8 mA	4.2 volts
60%	0.6 mADC	0.6 volts DC	3.0 volts DC	6.0 volts DC	13.6 mA	3.4 volts
40%	0.4 mADC	0.4 volts DC	2.0 volts DC	4.0 volts DC	10.4 mA	2.6 volts
20%	0.2 mADC	0.2 volts DC	1.0 volts DC	2.0 volts DC	7.2 mA	1.8 volts
0%	0.0 mADC	0.0 volts DC	0.0 volts DC	0.0 volts DC	4.0 mA	1.0 volts
Allowed error 0.25% Units	±0.0025 mA	±0.0025 volts	±0.0125 volts	±0.025 volts	±0.04 mA	±0.01 volts
Allowed error 0.5% Units	±0.005 mA	±0.005 volts	±0.025 volts	±0.05 volts	±0.08 mA	±0.02 volts

Table 1 For Checking Linearity of Current Transducers

Location of Trimpots on the MCT series of current transducers.

**MCT5-005A
MCT5-001A**

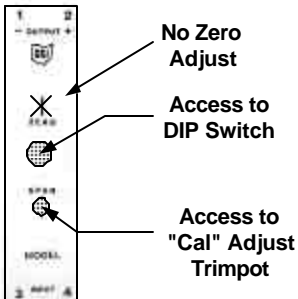

**MCT5-005E2
MCT5-001E2**

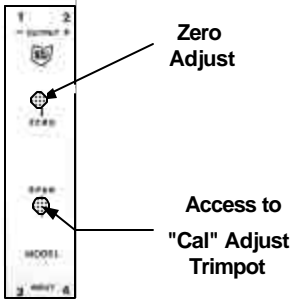

**MCT5-005E
MCT5-001E**

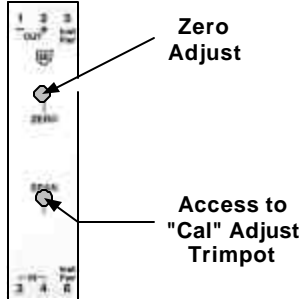

CONNECTIONS & DIMENSIONS

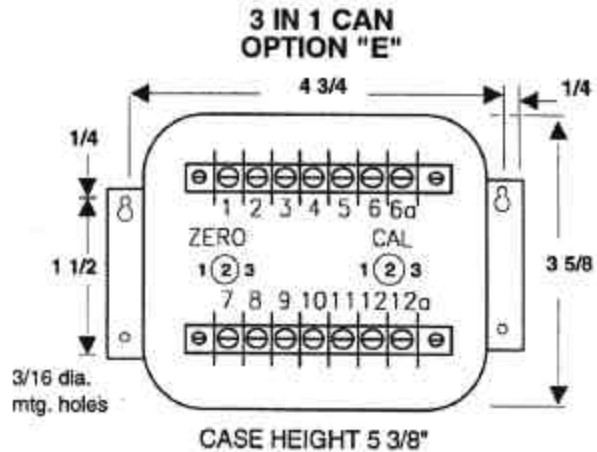
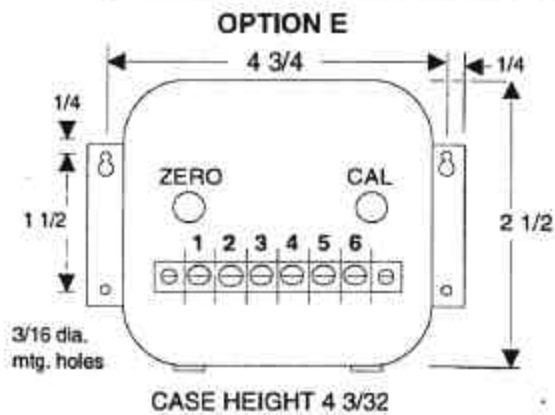
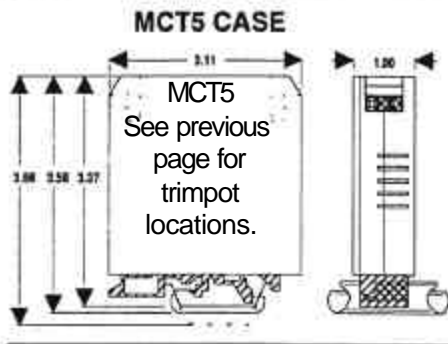
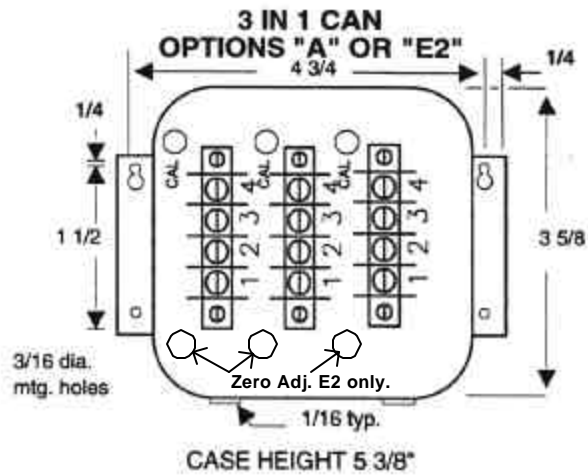
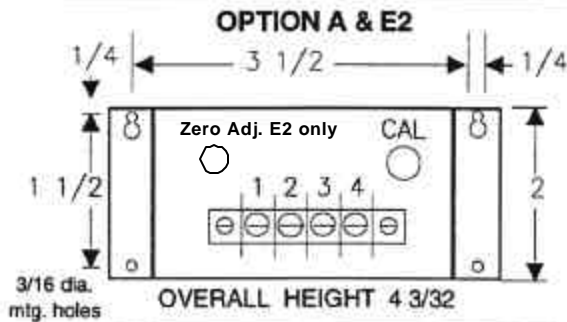
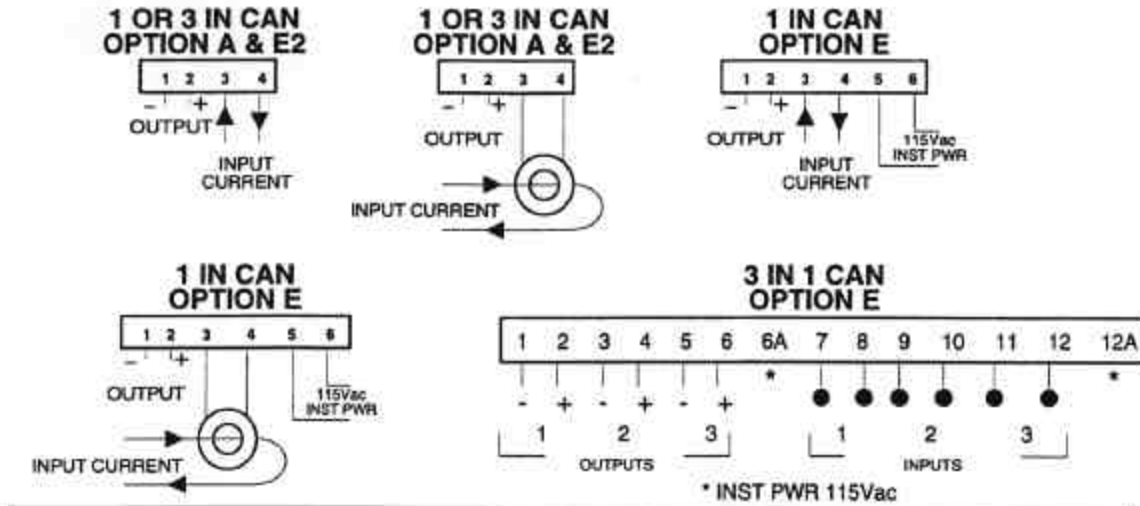

TEST SETUP FOR CURRENT TRANSDUCERS WITH OPTION E2 -- THE LOOP POWERED 4 TO 20 mADC OUTPUT.

Voltage source must be in the loop as shown.

