

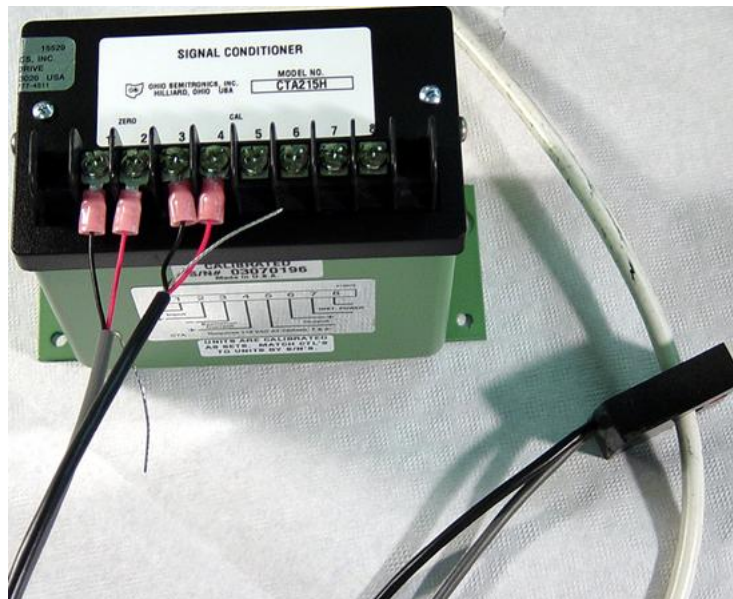

CTL- SERIES HALL EFFECT SENSORS CTA SERIES CONDITIONERS

Operation, Calibration and Troubleshooting Manual



Valid for all current catalog CTL sensor and CTA conditioner sets. Refer to the standard catalog product specification sheets for CTL & CTA to locate your particular models (not included in this manual). OSI offers post-sale calibration services on all manufactured products.

Caution: Use of this manual by qualified electrical personnel.

Ohio Semitronics, Inc.
4242 Reynolds Dr.
Hilliard Oh. 43026
1-800-537-6732
www.ohiosemitronics.com

3/12/2009 Rev C

CTL Transducer Series Description:

The model CTL- current transducers, also known as Hall-effect sensors, can be provided as a stand-alone item or in combination with a CTA signal conditioner. The CTL is a non-contact device that measures DC, AC or the combination of both in a cable, cable bundle or bus bar.

Model CTL transducers are available in a variety of shapes & sizes with current ratings from 35A to 40000A. Unlike traditional current “transformers”, Hall-effect transducers are built using a toroid core with one or more gaps. Inside each gap a 4 wire Hall-effect probe is installed to measure the magnetic flux providing a linear output proportional to the measured current flowing through the window. Model CTLs are available in either a solid-core or optional split-core design. Split core models include latches that allow the user to easily install the two halves easily around the existing cable, cable bundle or bus.

Model CTL transducers require four external connections. Two wires provide input excitation current, also known as the sensors instrument power or control current that is typically 200mAdc. This constant current supply is provided externally by the user in the case where a CTL is being used without a CTA signal conditioner. The other 2 wires are for the transducer’s output expressed in millivolts. The transducer output is directly proportional to the excitation current level and the measured conductor current (and waveform) flowing through the window. Typical millivolt output ratings vary with each model depending on current rating (from 35mV to 200mV). Refer to the product specification sheet for details about measuring ranges and outputs. Refer to figure 4 for wire coding details.

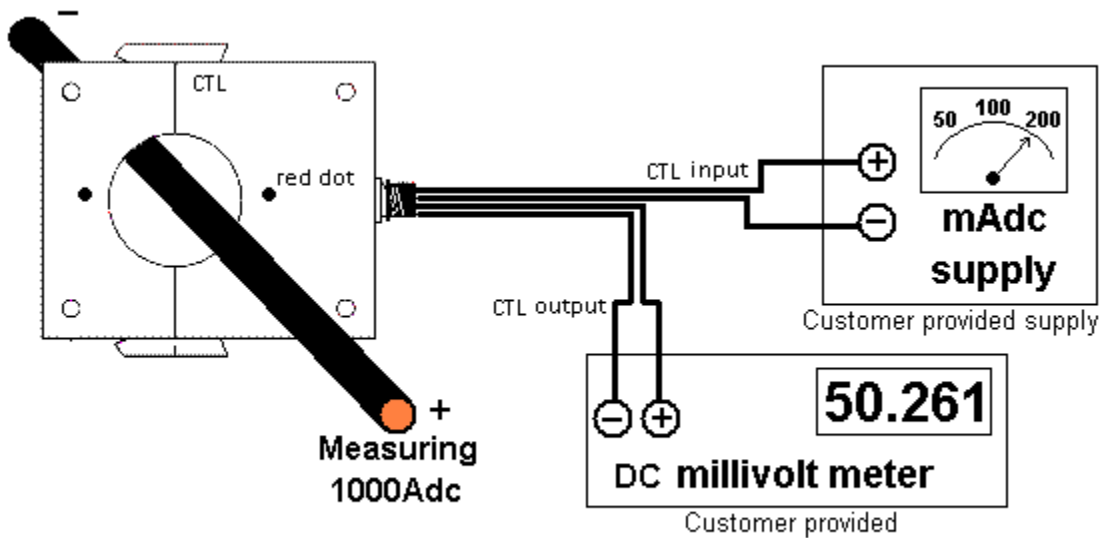

Figure 1

Figure 1 shows the wiring for model CTL-202TS/1000 intended for measuring 0 to 1000Adc. The CTL input excitation current is set at a constant 200mAdc. The rated output (with 1000Adc input) is specified at 50mVdc ($\pm 30\%$). This fixed output ranging from 35mVdc to 65mVdc is a characteristic of the Hall-effect probe installed in the transducer gap(s) and varies between each manufactured sensor.

Offset:

Zero offset is an inherent unbalance caused by a slight variation in the output of the Hall-effect probes used in the transducer. Typically the zero offset is $\leq \pm 2\text{mV}$.

Core residual contributes a small amount of offset which follows the current direction. When the current changes direction the offset reverses and vice-versa. The transducer’s core will retain this low level of magnetism as a result of previously applied full, or partial window measuring current. AC current alternating direction through the window tends to degauss the core and can eliminate some of the residual offset measured at the output.

Example Linearity Chart at 20% Intervals (with constant Excitation Current held at 200mAdc)

DC INPUT CURRENT	DC mV OUTPUT	DC EXCITATION CURRENT
1000A	50.261	200.00mA
800A	40.208	200.00mA
600A	30.156	200.00mA
400A	20.104	200.00mA
200A	10.052	200.00mA
0A	0.000	200.00mA

By adjusting the DC excitation current, the Full Scale (FS) output can be configured to read exactly 50mVdc. This follows the rule that the transducer output is proportional to the input *measuring current* and the *excitation current*.

Example Linearity at 20% Intervals (with constant Excitation Current held at 198.96mAdc)

DC INPUT CURRENT	DC mV OUTPUT	DC EXCITATION CURRENT
1000A	50.000	198.96mA
800A	40.000	198.96mA
600A	30.000	198.96mA
400A	20.000	198.96mA
200A	10.000	198.96mA
0A	0.000	198.96mA

Frequency:

CTL sensors operate successfully from DC to 1000Hz.

Note: a bandwidth of 0-5000Hz is possible when measuring small amplitude ripple. Caution in measuring fundamental frequencies above 1000Hz as this will cause a heating effect in the sensor core and over time will result in severe damage to the CTL.

The examples in figure 1 and the linearity chart show a DC measurement with a DC output. It is possible to vary the input measuring frequency and maintain the same frequency from the output of the sensor. Figure 2.

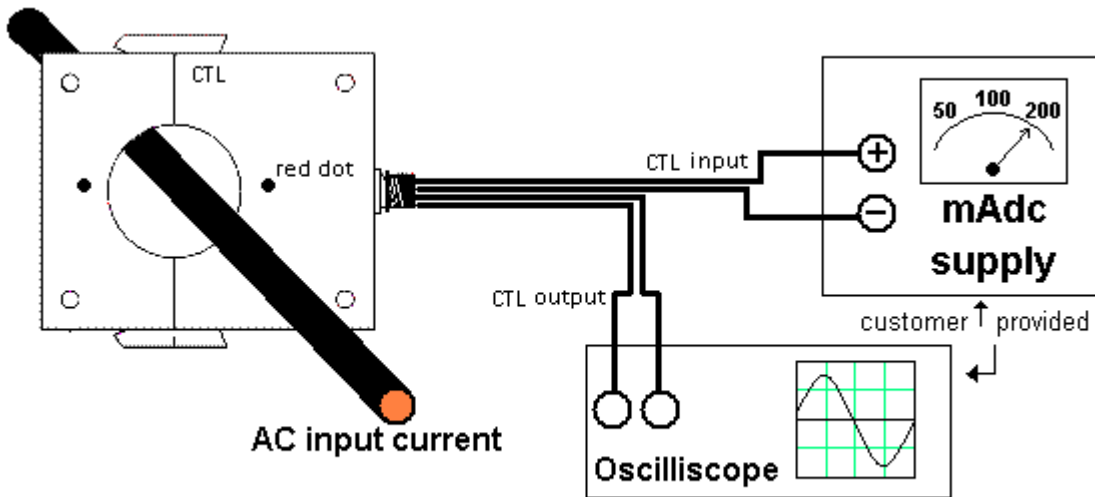

Figure 2

Over-current:

CTL transducers can handle 50 times continuous input over-current without damage and are not hazardous with open-output or open input wires with window current present.

CTA Signal Conditioner Series Description:

The CTA Signal Conditioner is designed to be used with Model CTL Hall-effect transducers. The signal conditioner operates with standard 115Vac instrument power. Optional instrument power voltages are available including 230Vac, 12Vdc (9-18Vdc range), 24Vdc (18-36Vdc range) and 48Vdc (36-60Vdc range). Figure 3.

The Model CTA Signal Conditioner performs two functions:

- Provides the input “excitation” constant current for CTLs.
- Provides a low drift differential input amplifier with associated electronic circuitry to provide an analog output based on the CTL millivolt input. Standard outputs are available 5V, 10V, 1mA, 4-20mA. Special outputs are available including 4-12-20mA.

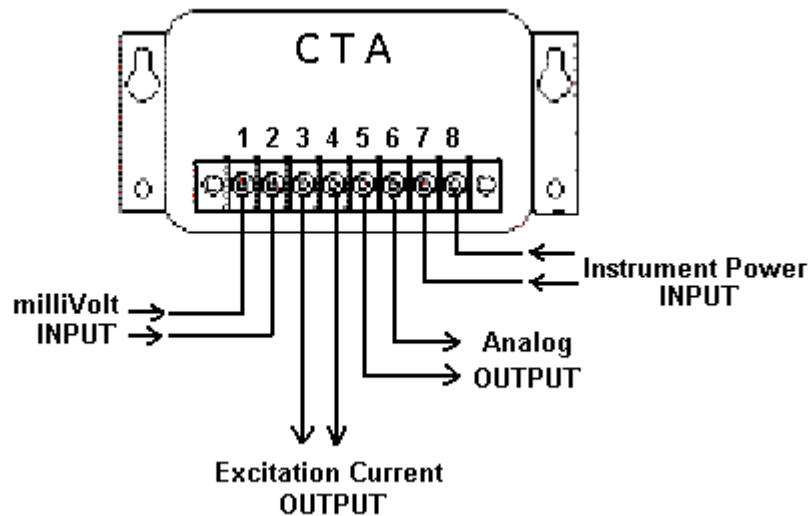

Figure 3

There are two fundamental types of CTA Signal Conditioners:

DIRECT. *The analog output is an exact copy of the input measured current waveform.*

Used mainly in DC applications with a response time of 40 microseconds, and can be used to measure rise times or distorted waveforms.

Available models: CTA201* & CTA212*

RMS. *The analog output is always DC.* The DC output is proportional to the RMS value of AC or DC input (or the combination of AC/DC). Output response is 200 milliseconds.

Available models: CTA213*, CTA214* & CTA215*

* = Variable model suffix for analog output option and input millivolt gain indicator.

See standard catalog specification sheet for CTL & CTA combinations that illustrate transducer and signal conditioner model matching along with analog output options, instrument power options, available cable lengths and wiring diagrams.

CTL and CTA matching:

Each CTL/CTA combination purchased together from OSI is calibrated as a matched set. The same serial number is applied to the transducer and signal conditioner.

Note: Prior to 1999 each CTL and CTA set was marked with different serial numbers. The sets were matched by a labeled reference to the corresponding component serial number.

Installing CTL and CTA:

Model CTL transducers are manufactured with mounting holes to facilitate bulkhead installation or the use of a customer-fabricated mounting bracket. The mounting holes are insulated allowing for the use of metal fasteners. Brackets should be fabricated **using non-ferrous material for best results**. Mount the transducer with the measuring current cable or current bus bar centered inside the middle of the window for best performance. Care should be taken so that the bus mounted CTL transducer is at least 12 inches (30cm) away from any right-angle bend in the bus. Adjacent magnetic fields can affect the accuracy of the CTL so take precaution to keep the transducer away from other power cables.

CTA signal conditioners are housed in a steel box with a base-plate that has 4 holes (2 key holes) for panel mounting. Keep CTA's dry and far away from noisy AC drives, inverters, etc. Do not mount the CTA in close proximity to an inverter or drive.

Polarity:

Installing the CTL transducer for DC current measurement the red dot must face the positive pole, or *source* for a +DC output on CTA terminal # 6. For AC measurements sensor polarity is not a factor for correct operation.

Hall-effect sensor cable and wire descriptions:

There are 2 different styles of the cables/wires depending on the sensor size and model. Figure 4.

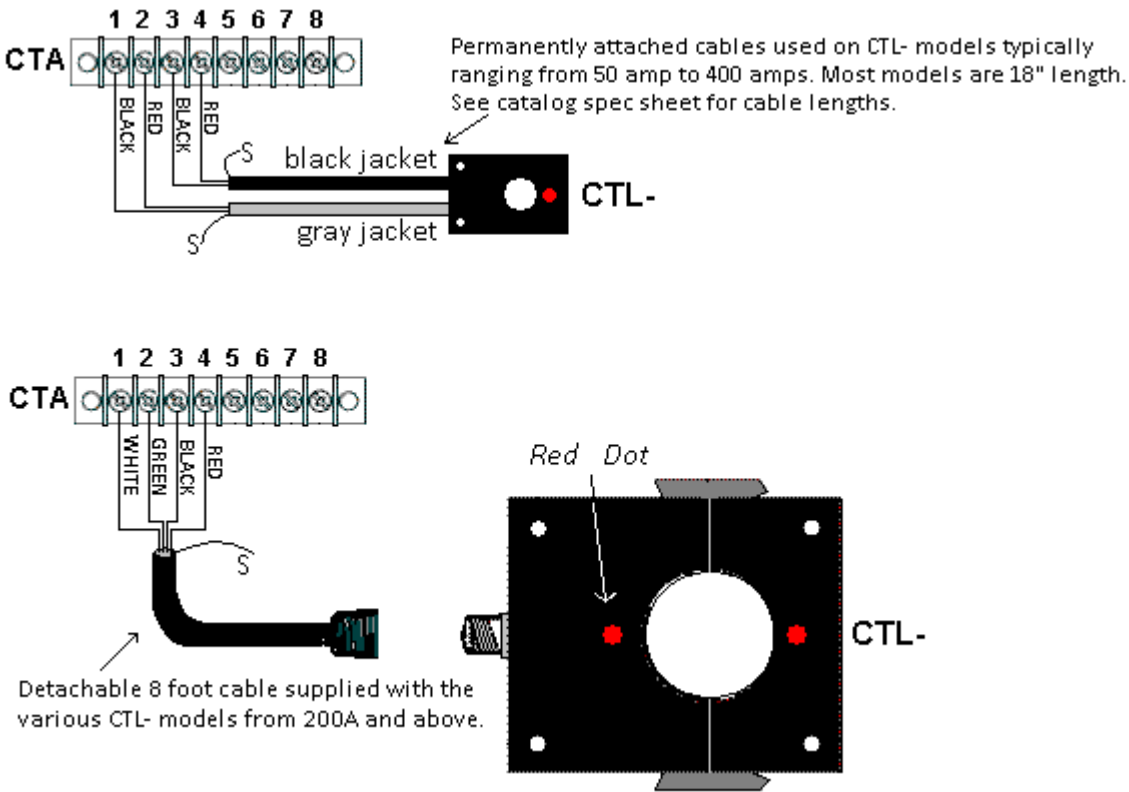

Figure 4

Shields:

A shielded wire provided on the CTL transducer should be connected to terminal 3 of the CTA signal conditioner terminal strip. Shield wire "S" shown unconnected in figure 4. The shield is not connected electrically inside the CTL and is utilized to reduce the influence of EMI in noisy environments.

CTA Output wiring:

It is recommended to use shielded twisted pair for the wiring of the CTA output terminals 5 & 6 to improve EMI immunity. **The output shield should be tied to ground at the receiving equipment end only. Do not ground this shield at the CTA side.**

Use of extension cables:

CAUTION: When extending the distance between the CTL transducer and the CTA signal conditioner by splicing in user-supplied cabling, avoid creating a distance of more than 50 feet. The extended cable length may affect the calibration set-point. A calibration check is recommended when using non-standard or user-supplied cable lengths. Consult OSI for the application and purchase of non-standard cables.

Factory Calibration and Certification:

Calibration services provided by the CtL/CTA manufacturer are the most accurate and reliable method of recalibration. OSI offers recalibration service for all CTL/CTA combinations using equipment traceable to N.I.S.T. A certificate of compliance with documented traceability with or without data points can also be requested. Contact OSI for a complete description of calibration certificates available and request a Return Material Authorization (RMA) number before shipping the CTL/CTA for repair and/or calibration.

Field Calibration of CTL/CTA sets:

Field calibration of a CTL/CTA combination may be performed provided the proper test equipment is available including an AC or DC current supply capable of providing full-scale current for the transducer.

An entire list of necessary equipment for the DC calibration and the AC calibration includes:

- DC current supply capable of supplying full window current for the model-sets with a **Direct-Measuring CTA:** (CTA201*, CTA212*). Figure 5.
- Current shunt. (typical outputs are 50mV or 100mV representing full rated current). For DC calibration the recommended shunt and metering source with an accuracy of 0.1%. Figure 5.
- Two Volt-meters. The meter with the highest resolution is recommended. Figure 5 or 8.
- **Precision resistor. (for calibrations with CTA outputs of 1mA_{dc}, 4-20mA_{dc} or 4-12-20mA_{dc} only) Recommended accuracy: 0.1%. Figure 5 or 8. (Resistor not shown).
- AC current supply capable of supplying full window current for the model-sets with an **RMS-Measuring CTA:** (CTA213*, CTA214*, CTA215*). Supply output Frequency Supply output Frequency (50Hz, 60Hz, 400Hz, etc.) can be used to meet the requirement of the CTL/CTA application. Figure 8.
- AC "Standard" - Includes Current Transformer. For AC calibration. Figure 8.

* CTA output and input gain variable. See CTA specification sheet.

** An output resistor is recommended for CTA's with a **current output** for conversion to voltage for metering. See spec sheet for "**Output Loading Range**". Choose resistor, then apply Ohms Law to verify the output voltage. Example: CTA with 1mA_{dc} output with a 1kΩ resistor across terminals #5 & #6.
 $E = I \times R$. (.001A x 1000ohm = 1V_{dc}).

Note: CTA outputs of 5V_{dc} and 10V_{dc} do not need a resistor. Wire output directly to Volt-meter.

Calibration Equipment setup: (DC input current)

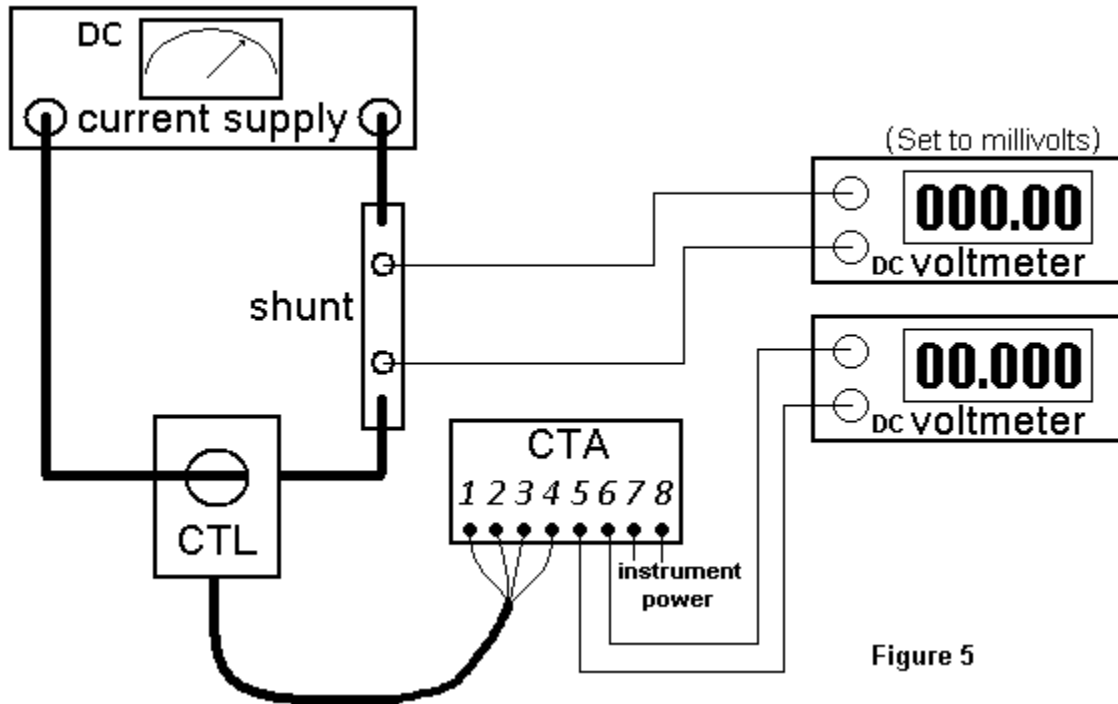

Figure 5

CTA Terminals 7 & 8 = instrument power connection. Recommend hi side to 8(+).
 For DC instrument power models: Terminal 8 = positive (+) DC connection.
 Terminals 5 & 6(+) = CTA Analog Output.

CAUTION: During calibration, wire CTL to CTA first, then apply instrument power. For disconnecting, turn off instrument power, then un-wire CTL from CTA.

Amp-Turns:

The available current supply may not have a full range that meets the Sensor's rated current. Running multiple turns through the sensor window (equally spaced throughout the entire window), provides an effective and accurate way to achieve full current (for both DC or AC calibration). An example of DC setup is shown in figure 6.

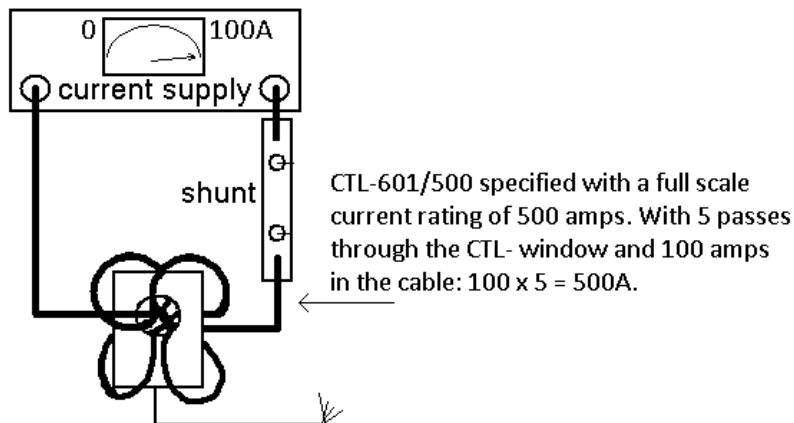

Figure 6

Run amp-turns cables evenly around the sensor as shown for best results.

DC Unidirectional Calibration: (Direct measuring CTA201* & CTA212*)

1. Face red dot on the CTL transducer towards the positive source of the DC current supply.
2. Convert CTA with outputs 0-1mAdc or 4-20mAdc to a voltage using a precision 0.1% resistor.
(Recommend 1k Ω for 1mAdc. 250 Ω for 4-20mAdc).
3. Wire the CTL to CTA terminals 1-4. Apply the rated CTA instrument power at terminals 7 & 8+ (hi side).
4. Turn on current supply and ramp up to full rated CTL window current.
5. Observe shunt output on voltmeter (set for DC) indicating full input measuring current setting.
6. Reduce current back down to zero. This adds residual to the transducer core.
7. Adjust the CTA “zero” potentiometer to indicate a zero output on the meter connected to CTA terminals 5 & 6+.
See Figure 7 for adjustment pot locations. For CTA’s with 4-20mAdc option, the zero pot is used to set the 4mAdc (1Vdc) output point. All other model/outputs will be set to 0.000Vdc.
8. Turn on current supply and ramp up to full rated CTL- current. Observe shunt-meter and CTA output meter.
9. Adjust CTA “cal” potentiometer to the CTA’s rated full scale output.
10. Check linearity by comparing the shunt output to the CTA output by reducing the current supply and stopping periodically at 10% or 20% increments.
11. At zero current input, turn off current supply and remove CTA instrument power. DC calibration is complete.

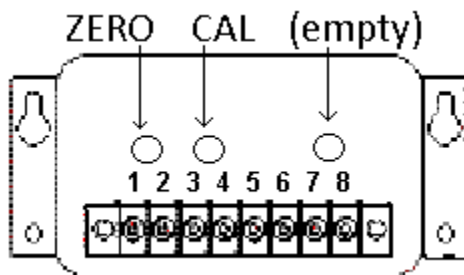

Figure 7

Calibration potentiometers are accessible through the top-lid under the label. Punch or cut label to access.

CAUTION: Do not apply instrument power to the CTA conditioner before wiring the CTL to the CTA. Connecting a CTL to a powered CTA can permanently damage the CTL.

DC Bi-Directional Calibration: (CTA201* or CTA212*Y42)

CTA signal conditioners with 4-20mAdc outputs are not designed to indicate reverse current input. Use model CTA212*Y42 (4-12-20mAdc output) for bi-directional current measuring. Zero potentiometer adjusts the 12.000mAdc point (3Vdc with 250 Ω load resistor).

CTL transducer models with the Y122 suffix utilize Hall-effect probes that have been carefully matched to provide high accuracy results in bi-directional measurement applications. These probes have very low zero offset and maintain excellent forward and reverse current measurement linearity.

For DC Bi-Directional Calibration, follow the same steps for DC unidirectional calibration. Then...

Reverse the CTL transducer on the supply line, facing the red dot towards the negative pole of the supply. Turn on current supply and ramp current up to full scale. The CTA output meter should read negative, but match the same value at full scale reverse current as it did with forward current.

Reduce current back to zero amps. Turn off supply. Negative current may add a negative residual effect to the core, leaving a negative offset at the CTA output meter. For best bi-directional accuracy, divide this offset by 2 and adjust the zero pot to this dividend value. This will balance the zero reading for “best” offset in bi-directional measurement applications.

Repeat forward calibration. Reverse CTL on the line with the red dot facing the positive pole.

Turn on current supply and ramp current up to full rated amps. Adjust calibration potentiometer for full scale output. Reduce current back down to zero. Turn off supply and remove instrument power to the CTA. The bi-directional calibration procedure is now complete.

AC Calibration: (RMS measuring CTA213*, CTA214*, CTA215*) (Figure 8)

- Use of an AC current supply with a shunt is not recommended due to its inductive effects upon the shunt creating an inaccurate reference.
- Running DC current (see DC calibration) to calibrate an AC designated CTL/CTA set is possible. Expect some minor differences at the zero and full scale settings when measuring AC current.
- AC wattmeter calibrators such as a Model Rotek 8000 with their corresponding current driver-extender (200A) can be used when available.
- Recommended (most cost-effective method) is AC calibration using an AC supply with an accurate reference standard that utilizes a current transformer and a conversion to DC output as shown.

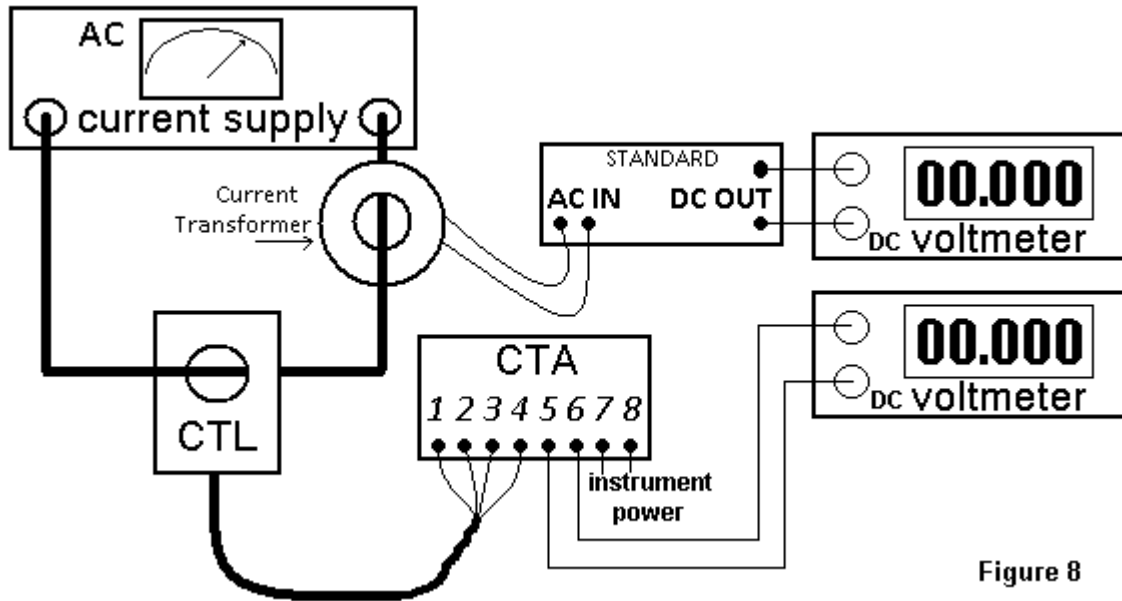

Figure 8

1. Red dot (CTL) polarity is not required on AC calibrations.
2. Convert CTA with output 1mAdc to "1 Volt" and 4-20mAdc to 1-5 volts using a precision 0.1% resistor. (Recommend 1k Ω for 1mAdc. 250 Ω for 4-20mAdc). If no resistor available, set output meter to milliamps.
3. Wire the CTL transducer to CTA terminals 1-4.
4. Apply the rated CTA instrument power at terminals 7 & 8+ (hi side).
5. Turn on current supply and ramp up to full rated CTL window current.
6. Observe standard output on voltmeter (set for DC) indicating full input measuring current setting.
7. Reduce current down slowly to zero and shut off current supply. This removes core residual.
8. Adjust CTA "zero" potentiometer to indicate a zero output on the voltmeter connected to CTA terminals 5 & 6+. For CTA's with 4-20mAdc option, the zero pot is used to set the 4mAdc "1 volt" output point.
9. Turn on current supply and ramp up to full rated CTL- current. Observe Shunt meter and CTA output meter.
10. Adjust CTA "cal" potentiometer to the CTA's rated full scale output.
11. Check linearity by comparing the reference standard output to the CTA output by reducing the current supply and stopping periodically at 10% or 20% increments.
12. At zero current input, turn off current supply and remove CTA instrument power. AC calibration is complete.

Troubleshooting CTL/CTA Transducer sets:

NO OUTPUT...

- * Check that instrument power has been applied to the CTA at terminals 7 & 8.
- * Check for proper polarity at terminals 7 & 8 (DC instrument power models: + to terminal 8).
- * Verify that the instrument power voltage has not exceeded the listed \pm range (reference specification sheet).
- * Check for "Open" CTL or "Open" CTA instrument power input. See **Resistance Checks...** below.
- * Check for active excitation current at CTA terminal 3 & 4. See **Test CTA Excitation Current Output** next page.
- * Check the volt-meter that is measuring the CTA output from terminals 5 & 6 to make sure it is set to DC Volts. An AC setting will give the appearance of "no output". However, applications for use with AC input and AC output will require the measuring device from terminals 5 & 6 to be set for AC (AC volt-meter, Oscilloscope, Analyzer... This type of AC to AC conversion will not work with RMS measuring CTAs).
- * Verify application. If requiring AC input and expecting DC (RMS) output and using a Direct Measuring CTA will not provide a DC output. (The output will be AC).

OPERATION IS OUTSIDE OF SPECIFIED TOLERANCE...

(Low output or high output with applied input current)

- * Check CTL hookup wiring for proper wire colors and jacket colors to their correct designated CTA terminals.
- * Check for mismatched serial number/sets. Non-matched serial numbers will operate with "out of tolerance" of up to 30% set-point and linearity based on full-scale. A recalibration of the set will correct this.
NOTE: Some sets particularly older sets will have different serial numbers that are calibrated together and matched with a separate label.
- * Check for lower than listed instrument power voltage being applied.
- * Verify the number of amp-turns through the CTL (only if running turns. Turns are not required. See figure 6). Count the number of turns in the center of the sensor window, not the outside number of turns (wraps).
NOTE: When running amp-turns through CTL current transducers or any current transformer the REAL usable maximum current is **full rating** divided by the **number of turns**.
- * Check that the CTL sensor is installed with the current measuring cable, cable bundle or bus centered. If running amp-turns, these turns must be evenly distributed around all 4 sides of the sensor.
- * Verify that the CTL sensor is not installed close to right angle bus or conductor turns. Any magnetic or metallic equipment or material in close proximity can affect the CTL/CTA accuracy.
- * Check that the CTL sensor halves (split-core models only) are clamped with red dot on same side. Attaching split-core sensors with the red dot on both sides of the sensor will not measure accurately.

HIGH OFFSET AT ZERO INPUT CURRENT...

- * If large zero offset and will not adjust with CTA "zero" potentiometer. See **Test Large Zero Offset....** next page.
- * Check CTL hookup wiring for proper wire colors and jacket colors to their correct designated CTA terminals.
- * Check for mismatched serial number/sets.
CAUTION: Applying instrument power to the CTA conditioner before wiring the CTL to the CTA may stress the Hall-effect probe creating a large un-adjustable offset.

Resistance checks with no instrument power applied:

1. Remove all connections/wires.
2. Set test meter to Ω .
3. Reading an "open" condition on either a CTL or CTA indicates a fault in the device.

- * CTL models 400A and lower: Input wires = 3 Ω to 9 Ω typical. Output wires = 18 Ω to 28 Ω typical.
- * CTL models 500A and higher: Input wires = 18 Ω to 28 Ω typical. Output wires = 10 Ω to 40 Ω typical.
- * CTA resistance at terminals 7 & 8: 120Vac models, ~ 220 Ω typical. 230Vac models, ~600 Ω typical.
- * CTA with DC instrument power option models: Terminal 7 & 8+ (will appear normal as "open" Ω).
With 8- reverse resistance: ~ 5.2k Ω .

Test CTA Excitation Current Output:

1. Connect the CTL to the CTA. Connect instrument power to terminals 7 & 8. *Turn on instrument power.*
2. Connect voltmeter (Set to DC volts) to terminals 3 & 4+ for a reading of .6Vdc to 1.8Vdc for CTL models of 400A and lower, or 3.6Vdc to 5.6Vdc at 3 & 4+ for CTL models of 500A and higher.
3. If this dc voltage is not in range, *turn off instrument power.* Remove CTL wires from terminals 3 & 4.
4. Set meter to DC milliamps. *Turn on instrument power* and check for 200mAdc $\pm 25\text{mA}$ at terminals 3 & 4+. If this reads zero mAdc, the CTA is defective. If 200mAdc is ok, then *turn off power* and check the CTL input/output resistance. See **Resistance checks...** previous page.

Test Large Zero Offset condition:

1. Connect the CTL to the CTA. Connect instrument power to terminals 7 & 8. *Turn on instrument power.*
2. To attempt a resetting of "zero" calibration, connect DC voltmeter to 5 & 6+ (set for DC volts) and adjust the 20 turn Zero potentiometer for zero current input setting.
If adjusting the zero trim potentiometer doesn't achieve a zero reading on the voltmeter, *turn off instrument power.* Disconnect the CTL wire from terminal 4 and leave it hanging open. *Turn on instrument power.* Adjust the zero trim potentiometer for zero volts. If the zero output is achieved, then the offset in the CTL output is too large to calibrate with the CTA. *Turn off power.*

Notes: Early versions of model CTA (EX: CTA101, CTA112, CTA115) has nominal 100mAdc Excitation Current. CTA with DC power options (-12, -24, -48) has factory setting of 175mAdc Excitation Current due to the limit of the DC converter component.
CTA with DC instrument power option is provided without a need for polarity at terminals 7 & 8. However, early versions CTA do require terminal 8 to be (+). As a general rule it is recommended to keep terminal 8(+) for wiring DC instrument power.

Acknowledgements:

Hall-effect probe concept/design: Dr. Warren E. Bulman
CTL/CTA product design: David W. Miller
Operation Guide author: Cory Forler
Publication Date: 3/12/2009
Revision C

© Ohio Semitronics Inc. 4242 Reynolds Dr. Hilliard Ohio USA 43026 Tel: 614-777-1005

<http://www.ohiosemitronics.com>